

MATERIALS	
SE	ZINC COATING "SENDZIMIR"
ZC	HDG
04	STAINLESS STEEL AISI 304L
16	STAINLESS STEEL AISI 316L

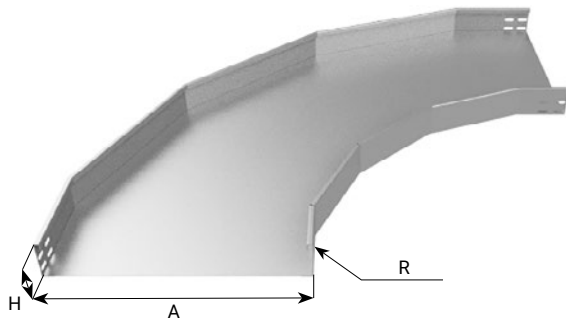

PLANE ELBOWS 90° (AR)								COVERS				
CODE			DIMENSIONS (mm)			THICKNESS (mm)	WEIGHT (Kg/mt)	CODE	DIMENSIONS (mm)		THICKNESS (mm)	WEIGHT (Kg/pcs)
GROUP	MATERIAL	TYPE	A	H	R				GROUP	A		
AR	ZC	P90	50	50	150	1,5	0,60	CA ZC P90	50	1	0,20	
AR	ZC	P90	75	50	150	1,5	0,80	CA ZC P90	75	1	0,25	
AR	ZC	P90	75	75	150	1,5	0,90	CA ZC P90	75	1	0,25	
AR	ZC	P90	100	50	150	1,5	0,90	CA ZC P90	100	1	0,30	
AR	ZC	P90	100	75	150	1,5	1,05	CA ZC P90	100	1	0,30	
AR	ZC	P90	100	100	150	1,5	1,20	CA ZC P90	100	1	0,30	
AR	ZC	P90	150	50	150	1,5	1,30	CA ZC P90	150	1	0,50	
AR	ZC	P90	150	75	150	1,5	1,40	CA ZC P90	150	1	0,50	
AR	ZC	P90	150	100	150	1,5	1,60	CA ZC P90	150	1	0,50	
AR	ZC	P90	200	50	150	1,5	1,65	CA ZC P90	200	1	0,75	
AR	ZC	P90	200	75	150	1,5	1,85	CA ZC P90	200	1	0,75	
AR	ZC	P90	200	100	150	1,5	2,05	CA ZC P90	200	1	0,75	
AR	ZC	P90	300	50	150	1,5	2,60	CA ZC P90	300	1	1,20	
AR	ZC	P90	300	75	150	1,5	2,85	CA ZC P90	300	1	1,20	
AR	ZC	P90	300	100	150	1,5	3,05	CA ZC P90	300	1	1,20	
AR	ZC	P90	400	75	150	1,5	4,65	CA ZC P90	400	1	2,35	
AR	ZC	P90	400	100	150	1,5	5,00	CA ZC P90	400	1	2,35	
AR	ZC	P90	500	75	150	1,5	5,40	CA ZC P90	500	1	2,70	
AR	ZC	P90	500	100	150	1,5	5,75	CA ZC P90	500	1	2,70	
AR	ZC	P90	600	75	150	1,5	7,00	CA ZC P90	600	1	3,70	
AR	ZC	P90	600	100	150	1,5	7,40	CA ZC P90	600	1	3,70	

Other dimensions and thickness are on request



MATERIALS	
SE	ZINC COATING "SENDZIMIR"
ZC	HDG
04	STAINLESS STEEL AISI 304L
16	STAINLESS STEEL AISI 316L



PLANE ELBOWS 90° (AR-FC)								COVERS				
CODE			DIMENSIONS (mm)			THICKNESS (mm)	WEIGHT (Kg/mt)	CODE	DIMENSIONS (mm)		THICKNESS (mm)	WEIGHT (Kg/pcs)
GROUP	MATERIAL	TYPE	A	H	R				GROUP	A		
FC	ZC	P90	50	50	600	1,5	2,90	CA ZC P90	50	1	1,10	
FC	ZC	P90	75	50	600	1,5	3,20	CA ZC P90	75	1	1,30	
FC	ZC	P90	75	75	600	1,5	3,80	CA ZC P90	75	1	1,30	
FC	ZC	P90	100	50	600	1,5	3,60	CA ZC P90	100	1	1,70	
FC	ZC	P90	100	75	600	1,5	4,30	CA ZC P90	100	1	1,70	
FC	ZC	P90	100	100	600	1,5	4,90	CA ZC P90	100	1	1,70	
FC	ZC	P90	150	50	600	1,5	4,40	CA ZC P90	150	1	2,20	
FC	ZC	P90	150	75	600	1,5	5,10	CA ZC P90	150	1	2,20	
FC	ZC	P90	150	100	600	1,5	5,70	CA ZC P90	150	1	2,20	
FC	ZC	P90	200	50	600	1,5	5,30	CA ZC P90	200	1	2,80	
FC	ZC	P90	200	75	600	1,5	6,00	CA ZC P90	200	1	2,80	
FC	ZC	P90	200	100	600	1,5	6,80	CA ZC P90	200	1	2,80	
FC	ZC	P90	300	50	600	1,5	7,20	CA ZC P90	300	1	4,00	
FC	ZC	P90	300	75	600	1,5	8,00	CA ZC P90	300	1	4,00	
FC	ZC	P90	300	100	600	1,5	8,80	CA ZC P90	300	1	4,00	
FC	ZC	P90	400	75	600	1,5	11,10	CA ZC P90	400	1	6,00	
FC	ZC	P90	400	100	600	1,5	12,00	CA ZC P90	400	1	6,00	
FC	ZC	P90	500	75	600	1,5	12,40	CA ZC P90	500	1	6,80	
FC	ZC	P90	500	100	600	1,5	13,30	CA ZC P90	500	1	6,80	
FC	ZC	P90	600	75	600	1,5	14,90	CA ZC P90	600	1	8,50	
FC	ZC	P90	600	100	600	1,5	15,80	CA ZC P90	600	1	8,50	

Other dimensions, thickness and bend radius 300 are on request

Plane elbows

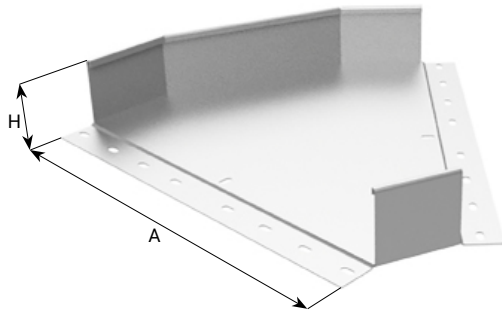

MATERIALS	
SE	ZINC COATING "SENDZIMIR"
ZC	HDG
04	STAINLESS STEEL AISI 304L
16	STAINLESS STEEL AISI 316L



PLANE ELBOWS 45° (AR)								COVERS			
CODE			DIMENSIONS (mm)			THICKNESS (mm)	WEIGHT (Kg/mt)	CODE	DIMENSIONS (mm)	THICKNESS (mm)	WEIGHT (Kg/pcs)
GROUP	MATERIAL	TYPE	A	H	R						
AR	ZC	P45	50	50	150	1,5	0,40	CA ZC P45	50	1	0,13
AR	ZC	P45	75	50	150	1,5	0,50	CA ZC P45	75	1	0,18
AR	ZC	P45	75	75	150	1,5	0,60	CA ZC P45	75	1	0,18
AR	ZC	P45	100	50	150	1,5	0,60	CA ZC P45	100	1	0,20
AR	ZC	P45	100	75	150	1,5	0,70	CA ZC P45	100	1	0,20
AR	ZC	P45	100	100	150	1,5	0,80	CA ZC P45	100	1	0,20
AR	ZC	P45	150	50	150	1,5	0,86	CA ZC P45	150	1	0,30
AR	ZC	P45	150	75	150	1,5	0,97	CA ZC P45	150	1	0,30
AR	ZC	P45	150	100	150	1,5	1,09	CA ZC P45	150	1	0,30
AR	ZC	P45	200	50	150	1,5	1,10	CA ZC P45	200	1	0,45
AR	ZC	P45	200	75	150	1,5	1,20	CA ZC P45	200	1	0,45
AR	ZC	P45	200	100	150	1,5	1,35	CA ZC P45	200	1	0,45
AR	ZC	P45	300	50	150	1,5	1,75	CA ZC P45	300	1	0,75
AR	ZC	P45	300	75	150	1,5	1,92	CA ZC P45	300	1	0,75
AR	ZC	P45	300	100	150	1,5	2,05	CA ZC P45	300	1	0,75
AR	ZC	P45	400	75	150	1,5	3,15	CA ZC P45	400	1	1,40
AR	ZC	P45	400	100	150	1,5	3,40	CA ZC P45	400	1	1,40
AR	ZC	P45	500	75	150	1,5	3,65	CA ZC P45	500	1	1,65
AR	ZC	P45	500	100	150	1,5	3,90	CA ZC P45	500	1	1,65
AR	ZC	P45	600	75	150	1,5	4,70	CA ZC P45	600	1	2,20
AR	ZC	P45	600	100	150	1,5	5,00	CA ZC P45	600	1	2,20

Other dimensions and thickness are on request

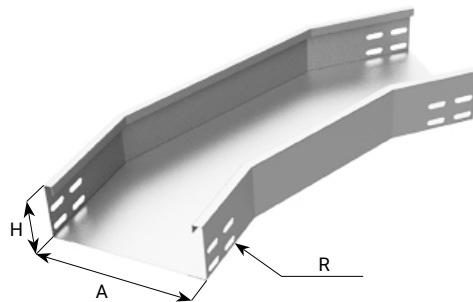

MATERIALS	
SE	ZINC COATING "SENDZIMIR"
ZC	HDG
04	STAINLESS STEEL AISI 304L
16	STAINLESS STEEL AISI 316L



PLANE ELBOWS 45° (AR-FC)								COVERS			
CODE			DIMENSIONS (mm)			THICKNESS (mm)	WEIGHT (Kg/mt)	CODE	DIMENSIONS (mm)	THICKNESS (mm)	WEIGHT (Kg/pcs)
GROUP	MATERIAL	TYPE	A	H	R						
FC	ZC	P45	50	50	600	1,5	600	CA ZC P45	50	1	0,50
FC	ZC	P45	75	50	600	1,5	600	CA ZC P45	75	1	0,65
FC	ZC	P45	75	75	600	1,5	600	CA ZC P45	75	1	0,65
FC	ZC	P45	100	50	600	1,5	600	CA ZC P45	100	1	0,90
FC	ZC	P45	100	75	600	1,5	600	CA ZC P45	100	1	0,90
FC	ZC	P45	100	100	600	1,5	600	CA ZC P45	100	1	0,90
FC	ZC	P45	150	50	600	1,5	600	CA ZC P45	150	1	1,10
FC	ZC	P45	150	75	600	1,5	600	CA ZC P45	150	1	1,10
FC	ZC	P45	150	100	600	1,5	600	CA ZC P45	150	1	1,10
FC	ZC	P45	200	50	600	1,5	600	CA ZC P45	200	1	1,40
FC	ZC	P45	200	75	600	1,5	600	CA ZC P45	200	1	1,40
FC	ZC	P45	200	100	600	1,5	600	CA ZC P45	200	1	1,40
FC	ZC	P45	300	50	600	1,5	600	CA ZC P45	300	1	2,10
FC	ZC	P45	300	75	600	1,5	600	CA ZC P45	300	1	2,10
FC	ZC	P45	300	100	600	1,5	600	CA ZC P45	300	1	2,10
FC	ZC	P45	400	75	600	1,5	600	CA ZC P45	400	1	3,20
FC	ZC	P45	400	100	600	1,5	600	CA ZC P45	400	1	3,20
FC	ZC	P45	500	75	600	1,5	600	CA ZC P45	500	1	3,50
FC	ZC	P45	500	100	600	1,5	600	CA ZC P45	500	1	3,50
FC	ZC	P45	600	75	600	1,5	600	CA ZC P45	600	1	4,40
FC	ZC	P45	600	100	600	1,5	8,30	CA ZC P45	600	1	4,40

Other dimensions, thickness and bend radius 300 are on request